

WOODWORKS: ADVANCED PROJECT DESK CADDY

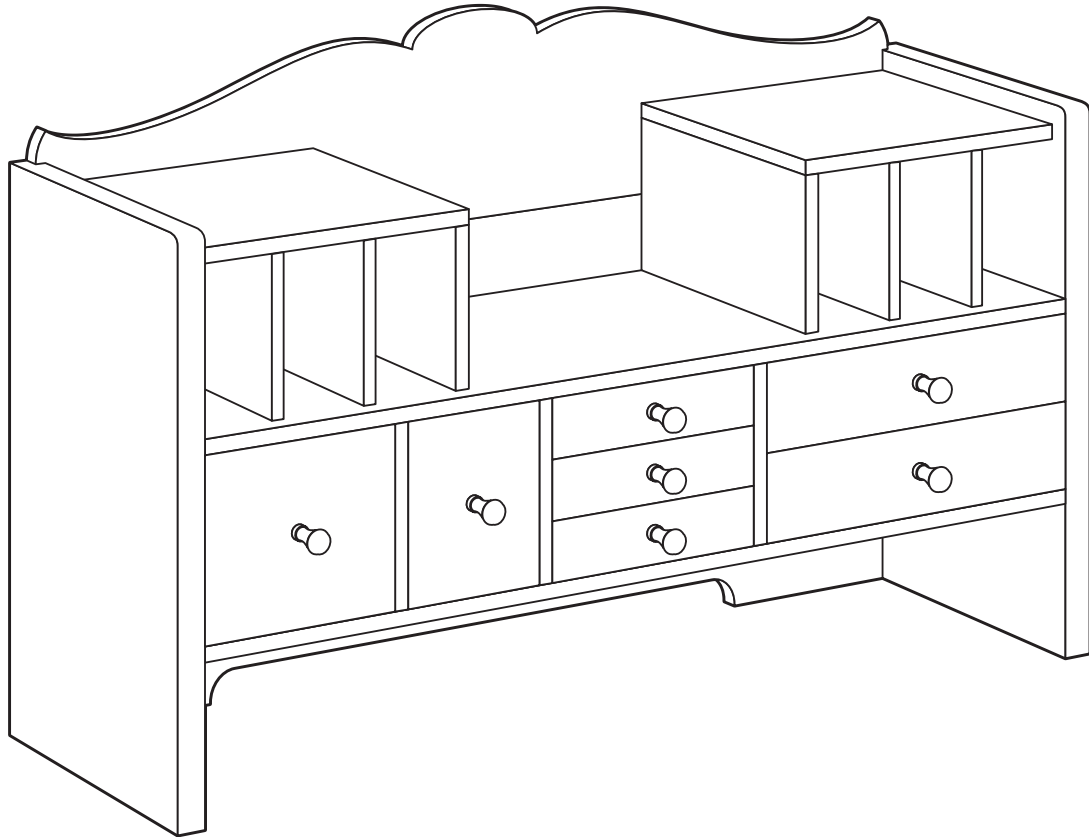

This desk caddy gives you the specialized storage features of a traditional secretary desk yet can sit atop any regular desk or computer work surface. Pigeonholes keep incoming mail organized while a variety of drawers hold stationery, pens and pencils and other supplies. The overall construction of the case uses sliding dovetail joints because they're strong, invisible and can be made with a router, as can the half-blind dovetails for the drawer boxes. You'll also get some practice with a scroll saw or jigsaw on the decorative top and with a lathe when you make the drawer pulls. And when it's all done, you'll learn more about applying and using stains and finishes to protect the wood and keep it looking beautiful.

TOOLS REQUIRED**Hand Tools**

- Mallet

Power Tools

- Table saw with combination rip/crosscut blade and dado blades
- Router and router table with straight-cutting and dovetail bits
- Router fence, used for sliding dovetails
- Drill with 1" dia. Forstner bit
- Scroll saw or jigsaw
- Orbital sander

Miscellaneous

- Pencil
- Tape measure
- Safety glasses
- Carpenter's glue
- 120-, 180- and 220-grit sandpaper
- Clean, lint-free cloths
- Respirator
- Gloves for finishing
- Mineral spirits (for oil-based stains and finishes)
- Water-filled metal container with tight-fitting lid (for oil-based stains and finishes)
- Minwax® Wood Finish™ Stain Brush or other good quality, natural bristle brush (for oil-based stains and finishes)

SHOPPING LIST**Recommended wood:** Cherry**Alternate wood:** Pine

3/4" x 11-1/2" cherry:	4 lin. ft.
1/2" x 11-1/2" cherry:	14 lin. ft.
3/4" x 9-1/2" cherry:	9 lin. ft.
1/2" x 7-1/2" clear pine:	8 lin. ft.
1/4" birch plywood:	One 20" x 30" piece

CUTTING LIST

Overall Dimensions:
36"w x 10-7/8"d x 20-3/4"h

Key	Part	Pcs.	Material	Dimensions
A	Sides	2	cherry	3/4" x 10-7/8" x 18-1/2"
B	Shelves	2	cherry	1/2" x 10-1/4" x 35-1/4"
C	Dividers	3	cherry	1/2" x 10-1/4" x 6-3/8"
D	Pigeonhole tops	2	cherry	1/2" x 9-1/2" x 10-5/8"
E	Pigeonhole end walls	2	cherry	1/2" x 9-1/2" x 5-1/2"
F	Pigeonhole dividers	4	cherry	3/8" x 9" x 5-1/4"
G	Back slats	3	cherry	5/8" x 8" x 35"
H	Drawer A front and back	2	cherry, pine	1/2" x 5-7/8" x 6-15/16"
I	Drawer A sides	2	pine	1/2" x 5-7/8" x 9-1/2"
J	Drawer A bottom	1	birch plywood	1/4" x 6-1/4" x 9-1/2"
K	Drawer B front and back	2	cherry, pine	1/2" x 5-7/8" x 4-15/16"
L	Drawer B sides	2	pine	1/2" x 5-7/8" x 9-1/2"
M	Drawer B bottom	1	birch plywood	1/4" x 4-5/8" x 9-1/2"
N	Drawer C front and back	4	cherry, pine	1/2" x 1-5/8" x 7-15/16"
O	Drawer C sides	4	pine	1/2" x 1-5/8" x 9-1/2"
P	Drawer C bottom	2	birch plywood	1/4" x 7-5/16" x 9-1/2"
Q	Drawer D front and back	2	cherry, pine	1/2" x 2-3/8" x 7-15/16"
R	Drawer D sides	2	pine	1/2" x 2-3/8" x 9-1/2"
S	Drawer D bottom	1	birch plywood	1/4" x 7-5/16" x 9-1/2"
T	Drawer E front and back	4	cherry, pine	1/2" x 2-7/8" x 12-7/16"
U	Drawer E sides	4	pine	1/2" x 2-7/8" x 9-1/2"
V	Drawer E bottom	2	birch plywood	1/4" x 11-7/8" x 9-1/2"
W	Drawer guides	14	pine	1/4" x 3/4" x 9-3/8"
X	Drawer pulls	7	cherry	3/4" dia. x 1" l (turned from 1 x 1 stock)

WOOD FINISHING PRODUCTS**Recommended Finish**

Prep: Minwax® Pre-Stain Wood Conditioner

Stain: Minwax® Wood Finish™ Golden Pecan

Finish: Minwax® Fast-Drying Polyurethane Semi-Gloss

Alternate Finish

Prep: Minwax® Pre-Stain Wood Conditioner

Stain: Minwax® Gel Stain Mahogany

Finish: Minwax® Wipe-On Poly Satin or Gloss

BEFORE YOU BEGIN

Good craftsmanship begins and ends with good work habits, so make the following steps part of your routine workshop practice. If you have any doubts or questions about how to proceed with a project, always discuss them with your shop instructor.

- Carefully and fully review plans and instructions before putting a tool to the project lumber.
- Work sensibly and safely. Wear safety goggles when doing work that creates flying chips and sawdust; wear the appropriate respirator whenever making sawdust or working with thinners or other solvents.
- At the end of every work session, clean up your shop area and put away all portable tools.

CUTTING AND ASSEMBLY PROCEDURE

1. Start by cutting only the case parts listed on the **CUTTING LIST**. Refer to Fig. 1 for the general layout of the entire piece. Don't cut the drawer parts until the entire piece is assembled, in case there are subtle changes to the opening sizes.

Woodworker's Tip: Before cutting parts that include half-blind dovetails, make a test piece to determine how long your jig makes the tails. Half-blind jigs do not all cut the tails to the same length. This variable will affect all the drawer parts and the pigeonhole end walls. It's safest to produce a sample half-blind joint first, then take measurements from that to determine the size of the rest of the pieces.

2. Rabbet the back edges of the sides (A) to receive the back slats (G).

3. Lay out the sliding dovetail slots on the sides and cut them with a router that's guided by a fence (Fig. 4).

Woodworker's Tip: After cutting the sliding dovetail sockets, note the change in depth of cut between the sides and the shelves. Then cut the tails on the ends of the shelves and slide them, partially, into their sockets. This will allow a precise socket-to-socket measurement to be taken for the dividers.

4. With a table-mounted router fitted with a fence (Fig. 5), cut the sliding dovetails on the ends of the shelves (B), the dividers (C), the pigeonhole tops (D) and the pigeonhole end walls (E).

5. Lay out and cut the dovetail slots on the shelves (B) to receive the dividers (C).

6. Lay out 1/8" x 3/8" blind dados in the top face of the top shelf (B) and the bottom faces of the pigeonhole tops (D) to receive the pigeonhole dividers (F). Also cut 1/8" x 1/2" dados in the top face of the top shelf to receive the pigeonhole end walls (E).

7. Set up the half-blind dovetail jig and use the hand router to cut the dovetails in the ends of the pigeonhole tops (D) and the pigeonhole end walls (E).

8. To finish the drawer detailing, cut 1/4" x 1/4" dados in the drawer fronts, back and sides to receive the drawer bottoms (J, M, P, S, V).

9. Lay out and cut the concave curve on the front edges of the pigeonhole dividers (F).

10. Make the tongue-and-groove joints on the appropriate edges of the back slats (G). Test-fit the slats in the back edges of the sides and rip the bottom slat as needed to make the top slat finish 3-1/4" above the sides.

11. Use the grid shown in Fig. 3 to lay out the scrollwork on the top-most back slat (G). Cut the design with a scroll saw or jigsaw and sand the edge to the finished shape.

12. In the bottom back slat, make a 1"-high, 23"-long cutout to serve as a pass-through for electrical cords. Give the inside corners of the cutout a 1" radius. Establish the radius with a 1" Forstner bit or cut it with a scroll saw.

13. After finish-sanding all the parts with 180- and 220-grit sandpaper, glue and assemble the shelves, dividers, sides and back, making sure that the case is dead square. Do not glue the back slats to each other or to the case; use only the specified screws. The back slats can be used to square the case and hold it square while the glue dries. Use a damp cloth or paper towel to wipe away any excess glue as soon as it appears.

14. Measure the resulting drawer openings and cut the drawer parts accordingly. See Fig. 6 to determine the locations of drawers A, B, C, D and E.

15. Use the dovetail jig to cut the half-blind dovetails in the drawer fronts, backs and sides (Fig. 2) (H, I, K, L, N, O, Q, R, T, U). Then set up either the router or the router table to cut the 1/4" x 3/4" slots in the drawer sides (I, L, O, R, U).

16. Assemble the drawers by gluing and joining the front, back and one side, slipping in the bottom and then gluing and joining the remaining side. A rubber or wooden mallet will help in tapping together the dovetails.

17. After waiting to let the glue set, test each drawer guide (W) in the slot with which it will be paired. Whenever the fit is too tight, sand the edge of the guide until it moves easily, but not at all loosely, through its respective slot.

18. Drill mounting holes in the guides. The rear hole should be horizontally elongated to allow for movement. The front hole should be vertically elongated to allow for adjustment.

19. Determine the locations of the drawer guides on the sides (A) and the dividers (C). Fasten the guides with #6 x 1/2" flat-head screws only, no glue.

20. Slide each drawer all the way into its respective opening. Adjust the drawer guides as needed. If necessary, plane or sand a drawer front, and possibly the sides, to produce a consistent gap between it and the case.

Woodworker's Tip: For the best appearance, cut all the drawer fronts from the same section of wood to get continuity in the grain.

STAINING AND FINISHING

Woodworker's Tip: Though you may be tempted to cut short your sanding, preparation and application time, don't do it. These tasks are very important steps in obtaining a high-quality finish. Remember, it is the finish, just as much as the fit and smoothness of the parts that will have great bearing on how people judge your craftsmanship. To ensure an excellent result, follow the steps listed in this section and also the instructions the finish manufacturer puts on its products.

FINISHING TIPS

- Test the stains and finishes you are planning to use on scraps of wood. On the back of the scrap, mark the stain/finish combination and the type of wood. Allow all samples to dry thoroughly before making your final finish selection. Save your samples for quick reference on future projects.
- All stains and finishes must be allowed to dry thoroughly between coats. Remember that drying times can vary due to humidity and other climatic conditions.
- If you have some leftover stain or finish, wipe the can rim so that stain or finish in the rim won't dry out and prevent the lid from forming a tight seal.
- Brushes used for oil-based finishes must be cleaned with mineral spirits.

21. Finish-sand any remaining rough spots with 220-grit sandpaper. Dust off the piece and wipe it carefully with a clean, lint-free cloth lightly dampened with mineral spirits.

Recommended Finish

22. Apply the Minwax® Wood Finish™ you've chosen using a natural-bristle brush and a clean, lint-free cloth following the directions on the can. The brush will help you get the stain into the inside corners. Allow the Wood Finish™ to set for about 5 to 15 minutes, then wipe off any excess. To achieve a deeper color, you may apply a second coat after 4-6 hours, repeating the application directions for the first coat. Allow the stain to dry for 24 hours before applying the protective clear finish.

Woodworker's Tip: When wiping off stain, make certain that your last wipe with the cloth goes with the grain of the wood. This way, any stain you might miss during wipe-off will be visually minimized by the wood grain.

23. Apply Minwax® Fast-Drying Polyurethane following the directions on the can. Use a good quality, natural-bristle brush. Allow the first coat to dry overnight.

24. The next day, sand all surfaces lightly with 220-grit or finer sandpaper using with-the-grain strokes. Dust off and wipe all surfaces with a cloth lightly dampened with mineral spirits. Apply a second coat of polyurethane and set the piece aside to cure overnight.

25. The following day, sand all surfaces lightly with 220-grit sandpaper. Dust off and wipe the piece with a cloth lightly dampened with mineral spirits and apply the third and final coat of polyurethane.

Alternate Finish

26. Apply the Minwax® Gel Stain you've chosen using a clean, lint-free cloth or natural-bristle brush. Follow the directions on the can. Allow the Gel Stain to set for about 3 minutes, then wipe off any excess with a clean, lint-free cloth. To achieve a deeper color, you may apply a second coat after 8 to 10 hours, repeating the application directions for the first coat. Allow the stain to dry for 24 hours before applying the finish.

Woodworker's Tip: When wiping off stain, make certain that your last wipe with the cloth goes with the grain of the wood. This way, any stain you might miss during wipe-off will be visually minimized by the wood grain.

27. Apply Minwax® Fast-Drying Polyurethane following the directions on the can. Use a good quality, natural-bristle brush. Allow the first coat to dry overnight.

28. The next day, sand all surfaces lightly with 220-grit or finer sandpaper using with-the-grain strokes. Dust off and wipe all surfaces with a cloth lightly dampened with mineral spirits. Apply a second coat of polyurethane and set the piece aside to cure overnight.

29. The following day, sand all surfaces lightly with 220-grit sandpaper. Dust off and wipe the piece with a cloth lightly dampened with mineral spirits and apply the third and final coat of polyurethane.

PRODUCT SAFETY

For your safety and the safety of those you work with, always read the safety warnings, which manufacturers print on their labels, and follow them to the letter.

WARNING! Removal of old paint by sanding, scraping or other means may generate dust or fumes that contain lead. Exposure to lead dust or fumes may cause brain damage or other adverse health effects, especially in children or pregnant women. Controlling exposure to lead or other hazardous substances requires the use of proper protective equipment, such as properly fitted respirator (NIOSH approved) and proper containment and cleanup. For more information, call the National Lead Information Center at 1-800-424-LEAD (in U.S.) or contact your local health authority.

DANGER: Rags, steel wool, other waste soaked with oil-based stains and clear finishes, and sanding residue may spontaneously catch fire if improperly discarded. Immediately place rags, steel wool, other waste soaked with this product, and sanding residue in a sealed, water-filled metal container. Dispose of in accordance with local fire regulations.

When using oil-based wood finishing products:

CAUTIONS: CONTAINS ALIPHATIC HYDROCARBONS.

Contents are **COMBUSTIBLE**. Keep away from heat and open flame.

VAPOR HARMFUL. Use only with adequate ventilation. To avoid over-exposure, open windows and doors or use other means to ensure fresh air entry during application and drying. If you experience eye watering, headaches, or dizziness, increase fresh air, or wear respiratory protection (NIOSH approved), or leave the area. Avoid contact with eyes and skin. Wash hands after using. Keep container closed when not in use.

Do not transfer contents to other containers for storage.

FIRST AID: In case of eye contact, flush thoroughly with large amounts of water for 15 minutes and get medical attention. For skin contact, wash thoroughly with soap and water. In case of respiratory difficulty, provide fresh air and call physician. If swallowed, call Poison Control Center, hospital emergency room, or physician immediately.

DELAYED EFFECTS FROM LONG-TERM OVEREXPOSURE.

Contains solvents which can cause permanent brain and nervous system damage. Intentional misuse by deliberately concentrating and inhaling contents may be harmful or fatal.

WARNING: This product contains a chemical known to the State of California to cause cancer and birth defects or other reproductive harm.

DO NOT TAKE INTERNALLY. KEEP OUT OF REACH OF CHILDREN.

CONFORMS TO ASTM D-4326. Contact a physician for more health information.

FIG 1. DESK CADDY DETAILS

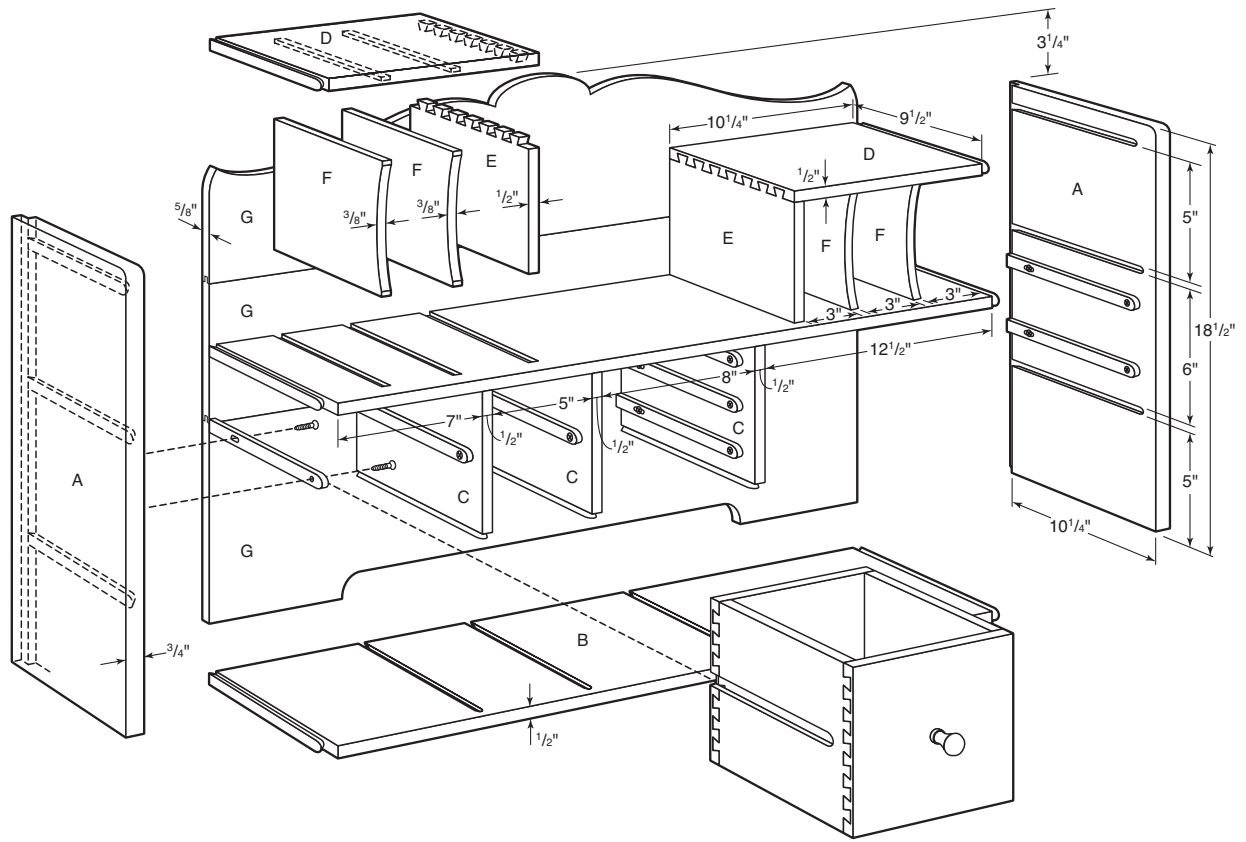

FIG 2. DRAWER ASSEMBLY

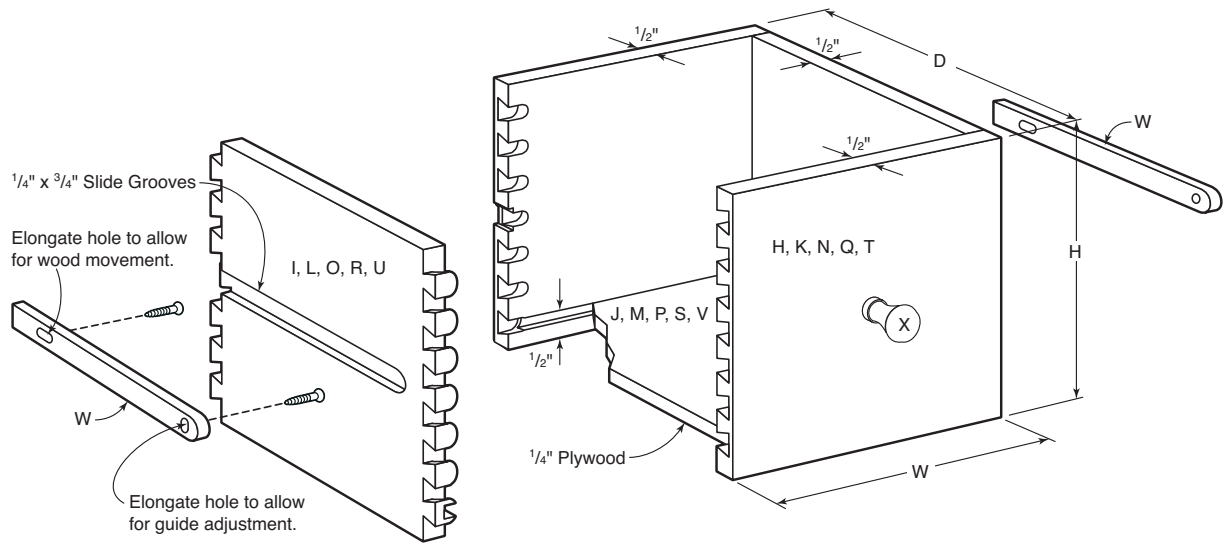

FIG 3. SCROLL GRID FOR TOP RAIL

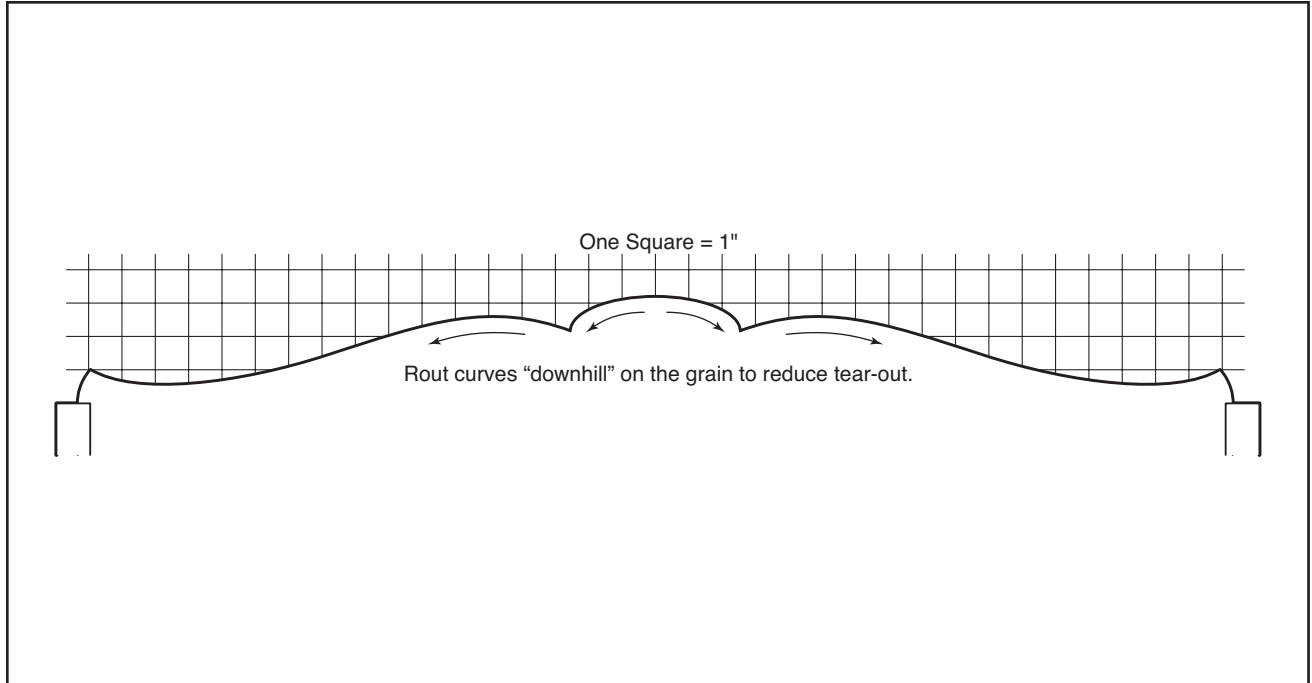

FIG 4. CUT SLIDING DOVETAIL GROOVE

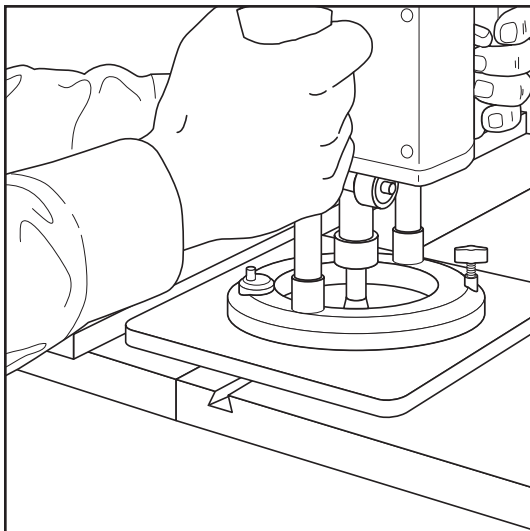

FIG 5. CUT SLIDING DOVETAIL TONGUE

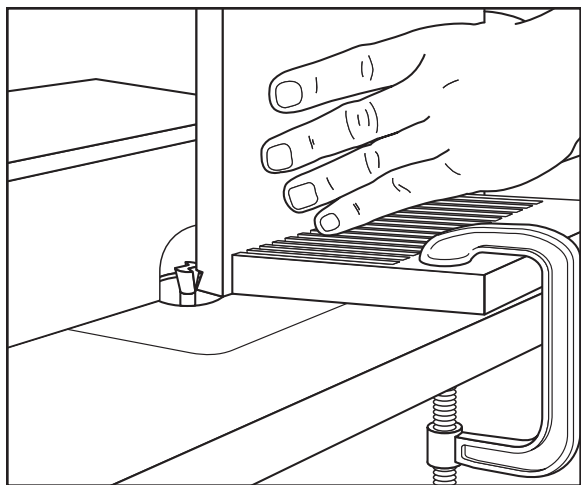

FIG 6. DRAWER LOCATIONS

